

Room Humidity/Temp Sensor

CE

Model HU-225

RoHS



- Ultra fast response cross-linked bulk polymer capacitive sensing element
- Proprietary hydrophobic and oleophobic ePTFE filter to protect the sensing element from condensation, fog, salt air, pollutants and other contaminants
- Wide 12-40 VDC/12-35 VAC unregulated supply voltage (humidity only)
- Two temperature compensated humidity output versions, 4-20 mA 2-wire or field selectable 0-5 VDC/0-10 VDC
- NIST traceable $\pm 2\%$ RH or $\pm 3\%$ RH calibration accuracy and $\pm 0.2^{\circ}\text{C}$ thermistor interchangeability or $\pm 0.1\%$ RTD accuracy

The HU-225 is an extremely fast, stable and accurate humidity/temperature transducer designed for harsh environments. The polymer humidity capacitance sensor is protected with an ePTFE (expanded Teflon) filter media. The Teflon protected cross-linked capacitive humidity sensor is not affected by prolonged exposure to condensing humidity, harsh environments, contaminants, fog or other extreme environmental conditions. Each unit is individually calibrated in an environmental test chamber to meet or exceed NIST traceable $\pm 2\%$ or $\pm 3\%$ accuracies. The HU-225 is temperature compensated for -30°F to 130°F (-35°C to 55°C) operation with negligible error. The HU-225 humidity/temp transducer has an aesthetically appealing ABS enclosure, which may be flush-mounted or fits a 2" by 4" handy box. Field selectable outputs, fully temperature compensated NIST traceable accuracy, non-interacting zero and span adjustments, short circuit and reverse polarity protected output, and a liberal five year warranty are some of the features which make the HU-225 the industry's highest performance, most reliable humidity/temperature sensor.

 **MAMAC SYSTEMS®**

HU-225

The HU-225 incorporates a cross-linked bulk polymer capacitive humidity sensor and precision NTC thermistor, platinum or balco RTD temperature sensor. Both temperature and humidity sensors are immune to most contaminants and at the same time provide a stable, repeatable, accurate humidity and temperature measurement with negligible hysteresis. The HU-225 utilizes sophisticated integrated circuits to provide a high level, fully conditioned, and temperature compensated humidity output. The temperature sensors are available with more than 16 different industry standard resistance to temperature curves offering compatibility to most if not all control systems. All thermistor sensors offer $\pm 0.2^{\circ}\text{C}$ interchangeability and accuracy. All thermistors strictly conform to industry standard R/T curves. The platinum RTD's are available with 100 ohm or 1,000 ohm DIN 43760 standards with $\pm 0.12\%$ accuracy at 0°C . All temperature sensors have more than $3.0 \text{ mW}/^{\circ}\text{C}$ heat dissipation constant.

On VDC output units (humidity only), two additional field selectable options are available; dual outputs 0-5 or 0-10 VDC, and dual unregulated supply voltages 12-35 VAC or 12-40 VDC. By merely moving a dip switch, one can select the desired output for the specific application. As far as supply voltage is concerned, the unit automatically configures for AC or DC, and no field selection is necessary. Another feature is that the output is fully protected from short circuit to ground or if the supply voltage is applied by mistake to the output. Past experience demonstrates that field related wiring problems do occur. Instead of denying this fact, this protection circuit is designed in to ensure trouble-free start-up. The VDC output unit is also designed to handle low impedance circuits. In fact, the unit can drive up to 1K ohm minimum. In this way, multiple controllers, indicators, or other devices can be paralleled to the output without performance degradation.

The mA output units (humidity only) function over a wide unregulated supply voltage range: 12-40 VDC without any affect on calibration or performance. The unit has reverse polarity

protection built in. As a result, it is next to impossible to damage the unit by wiring incorrectly.

By using sophisticated low dropout voltage regulators and CMOS integrated circuits, the mA output unit can drive very high output impedance. In fact, with only 12 VDC supply, the unit can drive 250 ohms. At 40 VDC, the unit is capable of handling up to a 1500 ohm load. In this way, the output loop can be tied in series to multiple controllers, indicators, and other devices without degrading the performance.

The humidity sensor is protected by an ePTFE (expanded Teflon) filter media that incorporates a proprietary process of expanding or stretching an ultra thin Teflon sheet during the manufacturing process to create less than 1.0 micron (0.000039 inch) pores or holes. The hydrophobic and oleophobic characteristics of Teflon force moisture, condensation and other contaminants to form a bubble larger than the pore size, and the surface tension of the Teflon stops the water or other contaminants from passing through the filter media, thereby protecting the sensing element. However, air with absorbed moisture can easily penetrate the filter media.

NIST traceable humidity standards are utilized to calibrate and certify the HU-225. Calibration data on each unit is archived digitally for SPC and QC purposes. All automated calibration systems are networked, and data is available online to numerous individuals at the same time. In this way, extremely high standards of quality and calibration integrity are maintained.

The HU-225 wall mount enclosure may be flush mounted on any flat surface or fits a standard 2" x 4" handy box. Louvers are provided on the top and bottom of the enclosure to ensure ample air flow for fast response. The enclosure also has additional features for ease of installation, including unplugable terminal block, easily-accessible zero and span trimmers, and conveniently located dip switches for field selection.

HU-225

HUMIDITY TRANSDUCER SPECIFICATIONS:

Accuracy*: $\pm 2\%$ / $\pm 3\%$ RH
Range: 0-100% RH
Hysteresis: $\pm 1\%$
Supply Voltage: 12-40 VDC
 12-35 VAC (VDC output units only)
Compensated Temp Range: -30°F to 130°F
 (-35°C to 55°C)
Load Impedance: 1.5K ohms max. at 40 VDC
 (mA output units)
 1K ohms min.
 (VDC output units)

* Includes non-linearity and non-repeatability

PLATINUM RTD SENSOR SPECIFICATIONS:

Accuracy: 0.12% at 0°C
Resistance: 100 or 1,000 ohm at 0°C
Standard: DIN 43760
Heat Dissipation: 3.0 mW/°C
R/T Characteristics: Refer to TI.700-11
 (See Temperature Sensor section)
Operating Temp Range: -30°F to 130°F
 (-35°C to 55°C)

THERMISTOR SENSOR SPECIFICATIONS:

Interchangeability: $\pm 0.2^\circ\text{C}$
Heat Dissipation: 3.0 mW/°C
R/T Characteristics: Refer to TI.700-11
 (See Temperature Sensor section)
Operating Temp Range: -30°F to 130°F
 (-35°C to 55°C)

GENERAL SPECIFICATIONS:

Environmental: 10-90%RH Non-Condensing
Enclosure: White ABS Plastic
Termination: Unpluggable screw terminal block
Wire Size: 12 Ga maximum
Weight: 0.5 lbs. (.25 kg)

CONFORMANCE & TESTING:

RoHS Compliant

EMC Testing:

BS EN 55022:1998, BS EN 55024:1998,
 EN 61000-3-3, EN 61000-4-2,
 EN 61000-4-3, EN 61000-4-4,
 EN 61000-4-5, EN 61000-4-6,
 EN 61000-4-11

ORDERING INFORMATION: HU-225-

Accuracy	Output	Temperature Sensor
$\pm 2\%$	mA (4-20 mA 2-wire)	1 100 ohm Platinum RTD 2 1,000 ohm Nickel RTD (5000 PPM) 3 1,000 ohm Platinum RTD 4 1,000 ohm Nickel RTD (6000 PPM) 5 1,000 ohm Balco RTD 7 10,000 ohm NTC thermistor (Type III) 8 10,000 ohm NTC thermistor (Carel)
$\pm 3\%$	VDC (0-5 VDC/0-10 VDC field selectable)	10 3,000 ohm NTC thermistor 12 10,000 ohm NTC thermistor (Type II) 13 5,000 ohm NTC thermistor 14 1,035 ohm Silicon PTC 15 100,000 ohm NTC thermistor 16 10,000 ohm NTC thermistor (Eliwell) 17 20,000 ohm NTC thermistor 18 2,252 ohm NTC thermistor 21 1,800 ohm NTC thermistor

Example: HU-225-2-mA-3: Humidity/Temperature Transducer, $\pm 2\%$ RH accuracy with 4-20 mA output and 1,000-ohm Platinum RTD.

For Resistance vs. Temperature Tables, please refer to TI.700-11.

CAUTION: Do not use in explosive/hazardous environment or with flammable/combustible media.

HU-225

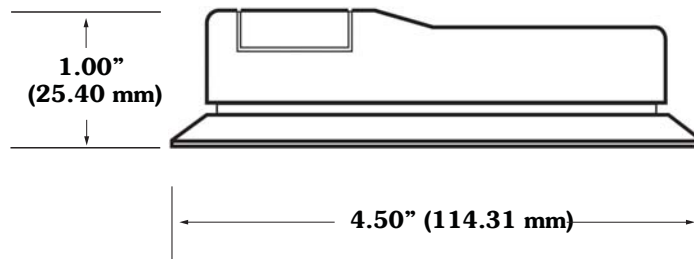
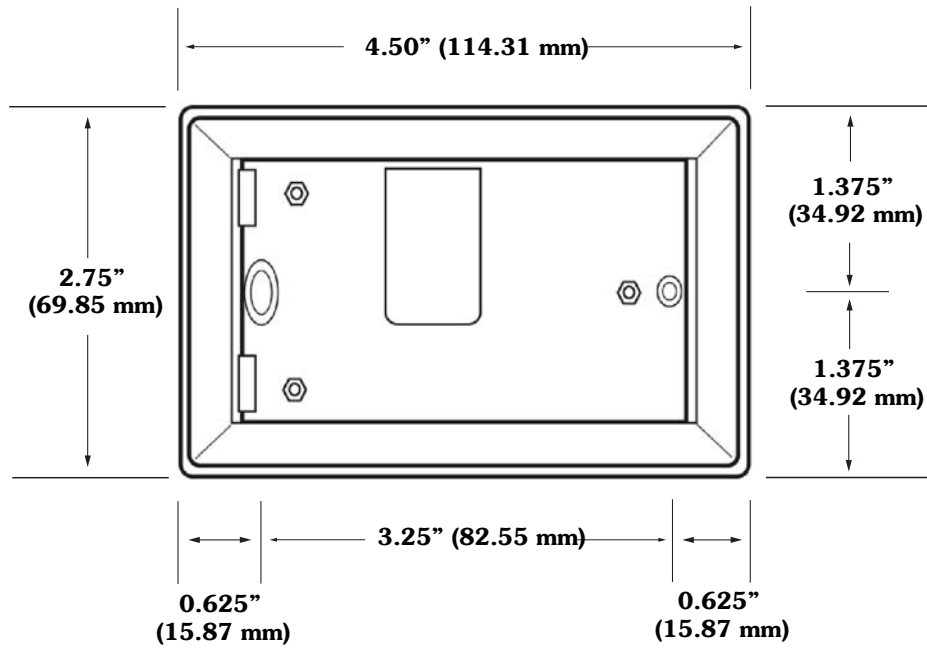

HU-225



MAMAC Systems is the leading global manufacturer of sensors, transducers, control peripherals and web browser based IP appliances. MAMAC products are used for HVAC and environmental controls, remote monitoring, alarming, energy metering and industrial automation.

All MAMAC products are manufactured in the USA.

WARRANTY: MAMAC Systems, Inc. and its subsidiaries (hereinafter referred to as MAMAC Systems) warrants its products to be free of defects in material and workmanship for a period of five (5) years from date of shipment. If a unit is malfunctioning, it must be returned to the factory for evaluation. A return authorization number (RMA) will be issued by the customer service department and this number must be written or prominently displayed on the shipping boxes and all related documents. The defective part should be shipped freight pre-paid to the factory. Upon examination by MAMAC Systems, if the unit is found to be defective, it will be repaired or replaced at no charge to the customer. However, this warranty is void if the unit shows evidence of being tampered with, damaged during installation, misapplied, misused, or used in any other operating condition outside of the unit's published specifications.

MAMAC Systems makes no other warranties or representations of any kind whatsoever, expressed or implied, except that of title. All implied warranties including any warranty of merchantability and fitness for a particular purpose are hereby disclaimed. User is responsible to determine suitability for intended use.

LIMITATIONS OF LIABILITY: The remedies of buyer set forth herein are exclusive and the total liability of MAMAC Systems with respect to this order, whether based on contract, warranty, negligence, indemnification, strict liability or otherwise, shall not exceed the purchase price of the product upon which liability is based. **In no event shall MAMAC Systems be liable for consequential, incidental or special damages.** MAMAC Systems reserves the right to change any specifications without notice to improve performance, reliability, or function of our products.

Every precaution for accuracy has been taken in the preparation of this manual, however, MAMAC Systems neither assumes responsibility for any omissions or errors that may appear nor assumes liability for any damages that result from the use of the product in accordance with the information contained in the manual.

